

PART NUMBER: CPE-244

DESCRIPTION: piezo audio transducer

SPECIFICATONS

operating frequency	5 ± 0.5 kHz	
rated voltage	12 V dc	
operating voltage range	9 ~ 16 V dc	
current consumption	35 mA max.	at 12 V dc
sound pressure level	80 dB min.	at 30 cm/12 V dc
tone	continuous	at 12 V dc
operating temperature	-30 ~ +85° C	
storage temperature	-40 ~ +95° C	
dimensions	ø14 x H10 mm	
weight	5 g max.	
material	PBT + 15% glass	
terminal	pin type	
RoHS	yes	

APPEARANCE DRAWING

tolerance: ±0.5

units: mm

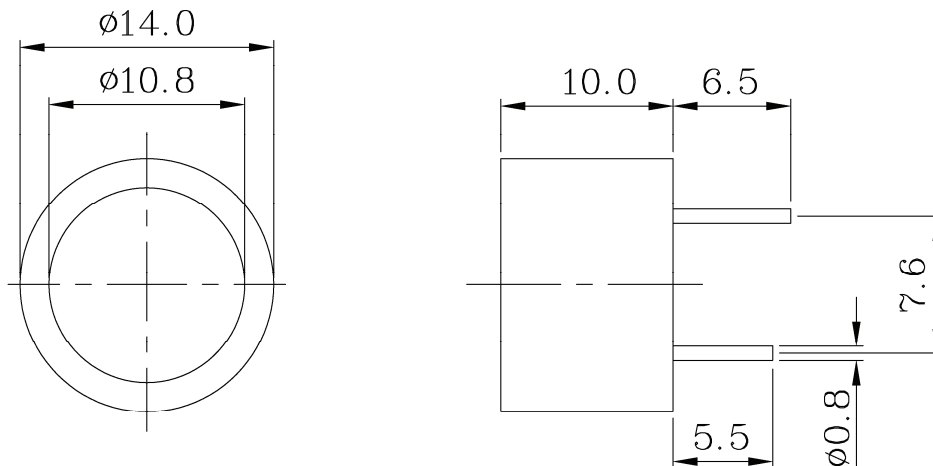

PART NUMBER: CPE-244

DESCRIPTION: piezo audio transducer

VOLTAGE: SOUND PRESSURE LEVEL / CURRENT CONSUMPTION

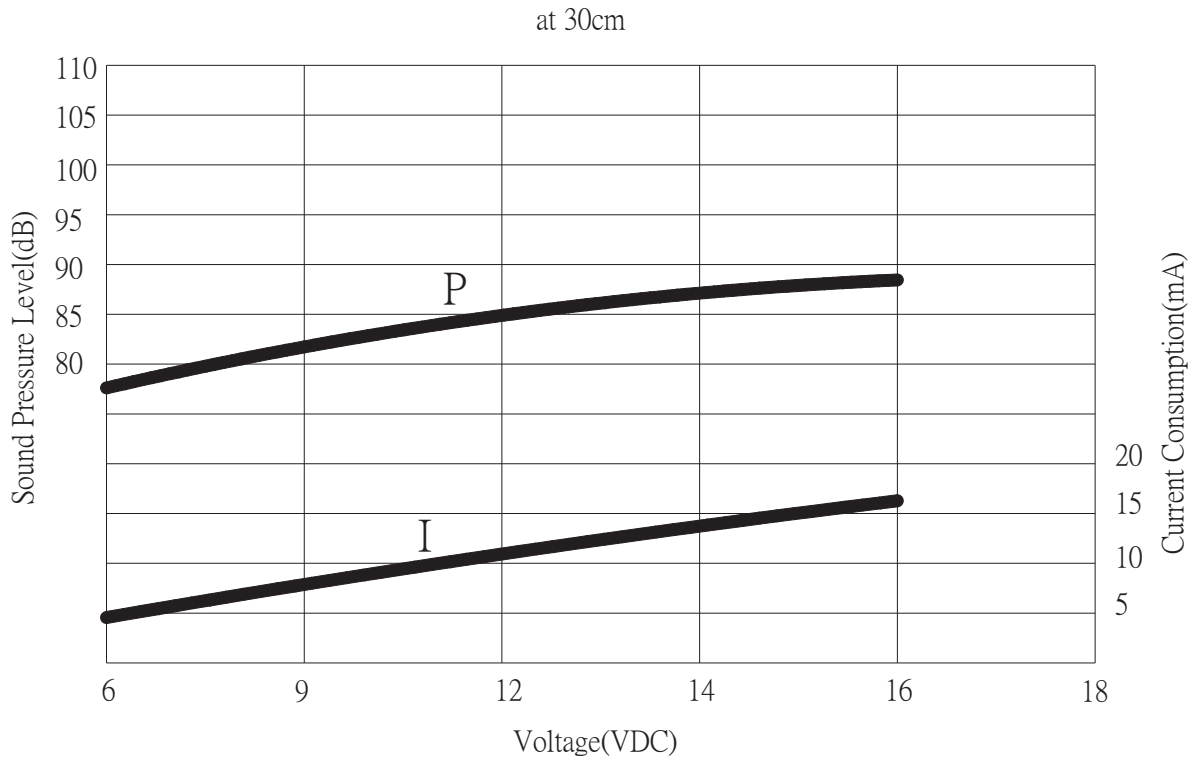

MEASUREMENT METHOD

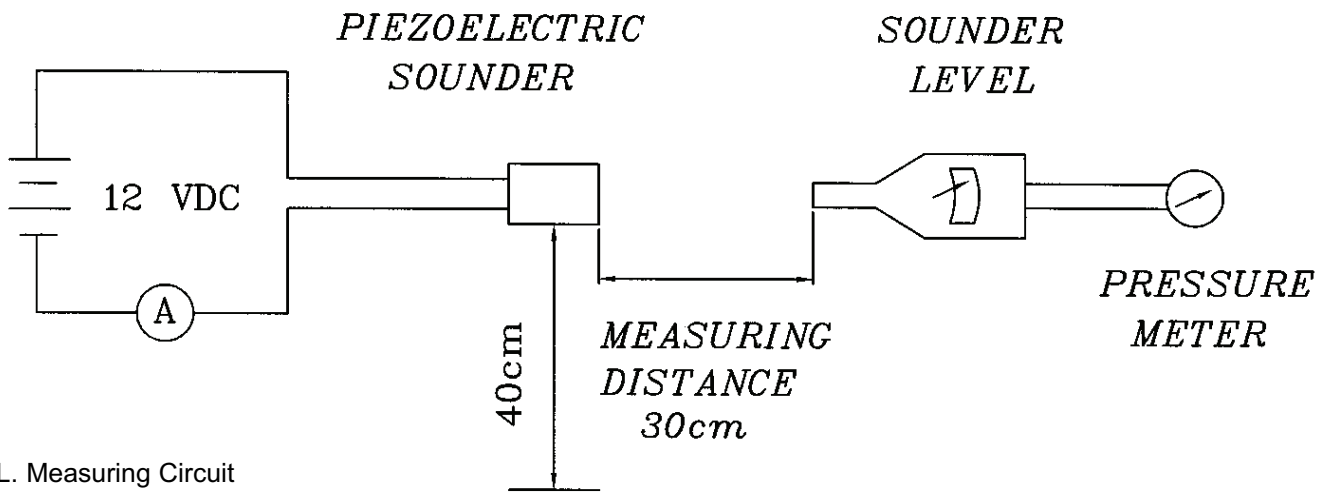

S.P.L. Measuring Circuit
 Mic: RION S.P.L. meter UC30 or equivalent
 S.G.: Hewlett Packard 33120A function generator or equivalent

PART NUMBER: CPE-244

DESCRIPTION: piezo audio transducer

MECHANICAL CHARACTERISTICS

item	test condition	evaluation standard
solderability	Lead terminals are immersed in rosin for 5 seconds and then immersed in solder bath of $270 \pm 5^\circ\text{C}$ for 3 ± 1 seconds.	90% min. of the lead terminals will be wet with solder (except the edge of the terminal).
soldering heat resistance	Lead terminals are immersed up to 1.5 mm from the buzzer's body in a solder bath of $300 \pm 5^\circ\text{C}$ for 3 ± 0.5 seconds or $260 \pm 5^\circ\text{C}$ for 10 ± 1 seconds.	No interference in operation.
terminal mechanical strength	The force of 9.8 N (1 kg) will be applied for 10 seconds to each terminal in each axial direction.	No damage or cutting off.
vibration	The buzzer shall be measured after applying a vibration amplitude of 1.5 mm with 10 to 55 Hz band of vibration frequency to each of the 3 perpendicular directions for 2 hours.	The value of oscillation frequency/current consumption should be $\pm 10\%$ of the initial measurements. The SPL should be within $\pm 10\text{dB}$ compared with the initial measurement.
drop test	The part will be dropped from a height of 75 cm onto a 40 mm thick wooden board 3 times in 3 axes (X, Y, Z) for a total of 9 drops.	

ENVIRONMENT TEST

item	test condition	evaluation standard
high temp. test	After being placed in a chamber at $+95^\circ\text{C}$ for 240 hours.	The buzzer will be measured after being placed at $+25^\circ\text{C}$ for 4 hours. The value of the oscillation frequency/current consumption should be $\pm 10\%$ compared to the initial measurements. The SPL should be within $\pm 10\text{dB}$ compared to the initial measurements.
low temp. test	After being placed in a chamber at -40°C for 240 hours.	
humidity test	After being placed in a chamber at $+40^\circ\text{C}$ and $90 \pm 5\%$ relative humidity for 240 hours.	
temp. cycle test	The part shall be subjected to 5 cycles. One cycle will consist of:	

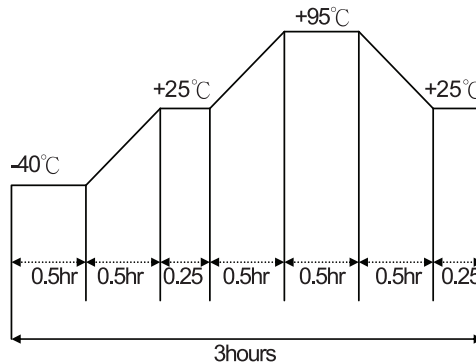

PART NUMBER: CPE-244**DESCRIPTION:** piezo audio transducer**RELIABILITY TEST**

item	test condition	evaluation standard
operating (life test)	1. Continuous life test: The part will be subjected to 48 hours of continuous operation at +70°C with rated voltage applied. 2. Intermittent life test: A duty cycle of 1 minute on, 1 minute off, a minimum of 5,000 times at room temp (+25 ±2°C) with rated voltage applied.	The buzzer will be measured after being placed at +25°C for 4 hours. The value of the oscillation frequency/current consumption should be ±10% compared to the initial measurements. The SPL should be within ±10dB compared to the initial measurements.

TEST CONDITIONS

standard test condition	a) temperature: +5 ~ +35°C	b) humidity: 45 - 85%	c) pressure: 860-1060 mbar
judgement test condition	a) temperature: +25 ±2°C	b) humidity: 60 - 70%	c) pressure: 860-1060 mbar

PART NUMBER: CPE-244

DESCRIPTION: piezo audio transducer

PACKAGING

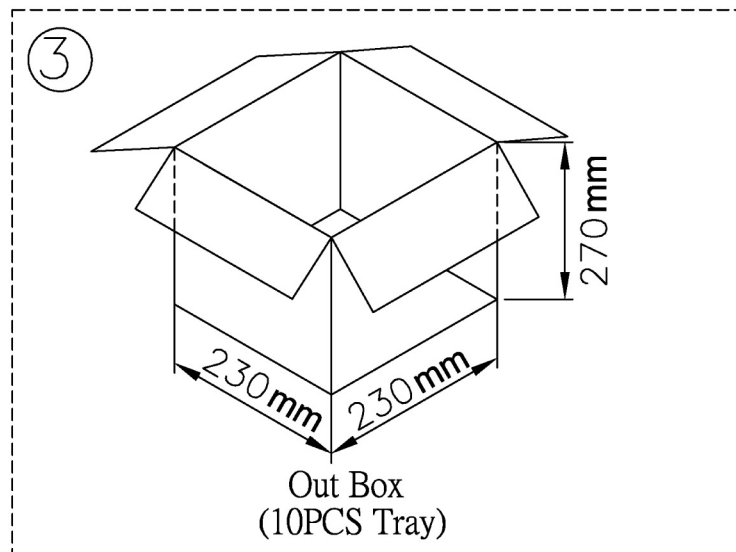
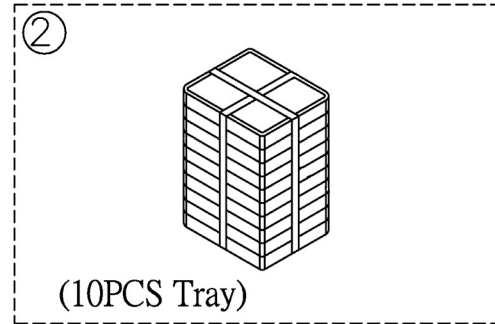
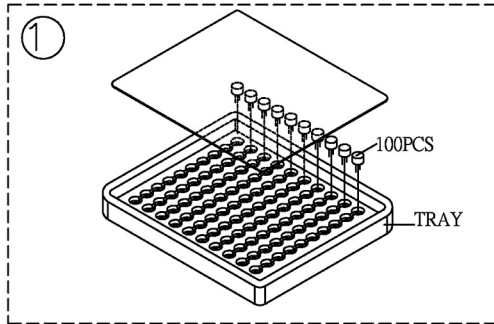

Tray		1x100PCS=100PCS
Out Box	230mmx230mmx270mm	10LAYERx100PCS=1000PCS